

playmobil®

6282



**WARNING:
CHOKING HAZARD**

Small parts. Not for children under 3 years.

”Ne concerne que les USA/CDN“

Wichtige Unterlagen, bitte sorgfältig aufbewahren !
Important: Please keep these instructions for future reference !
Documents importants, à conserver soigneusement !
Belangrijke documenten, bewaar deze zorgvuldig !

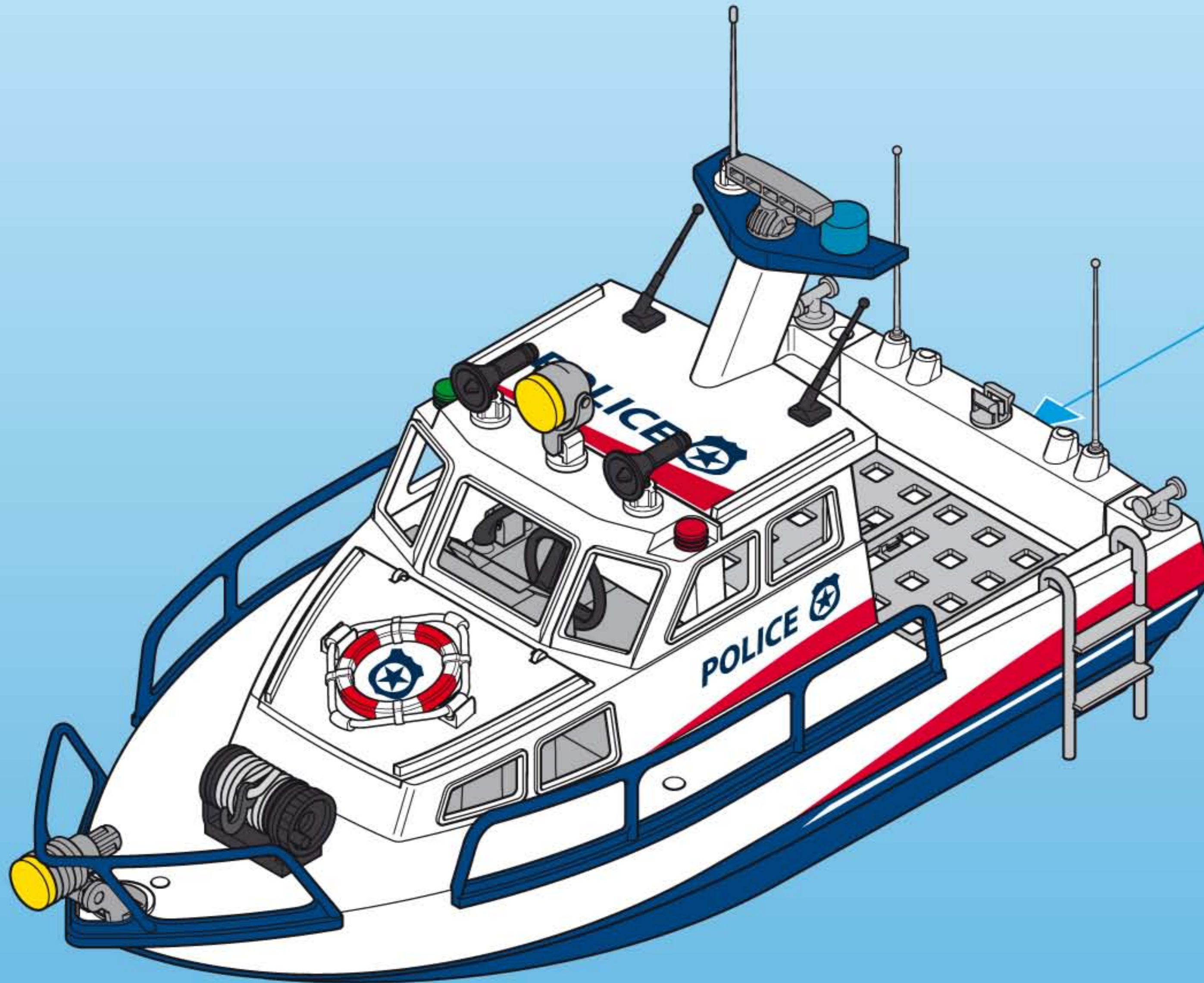

7350

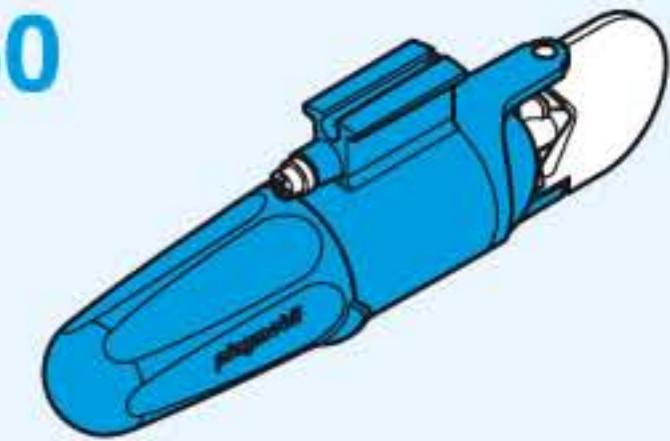

- Nachrüstbar mit Unterwassermotor
- Compatible with the underwater motor (sold separately)
- Monteur submersible, vendu séparément, s'adapte sur ce bateau

1

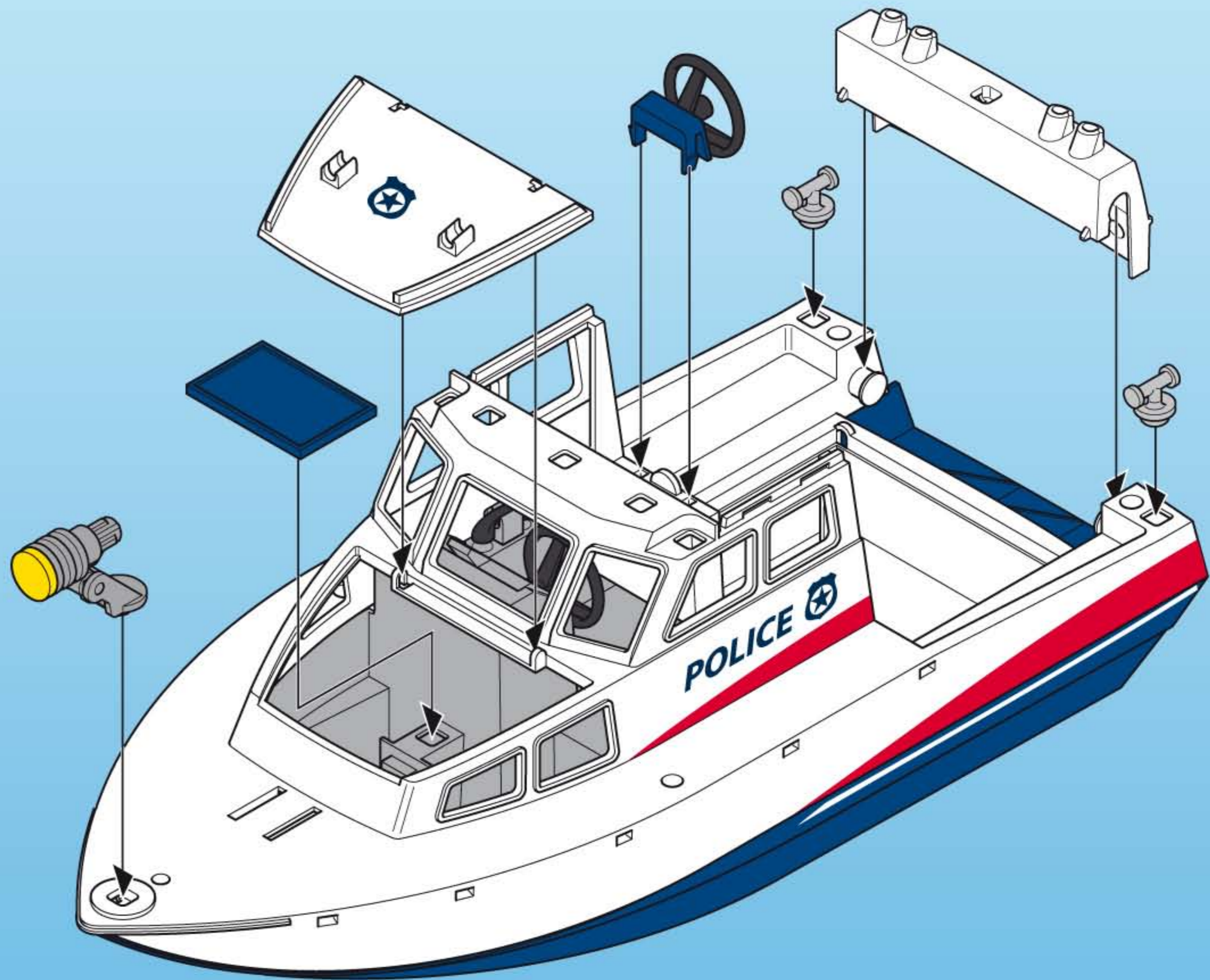
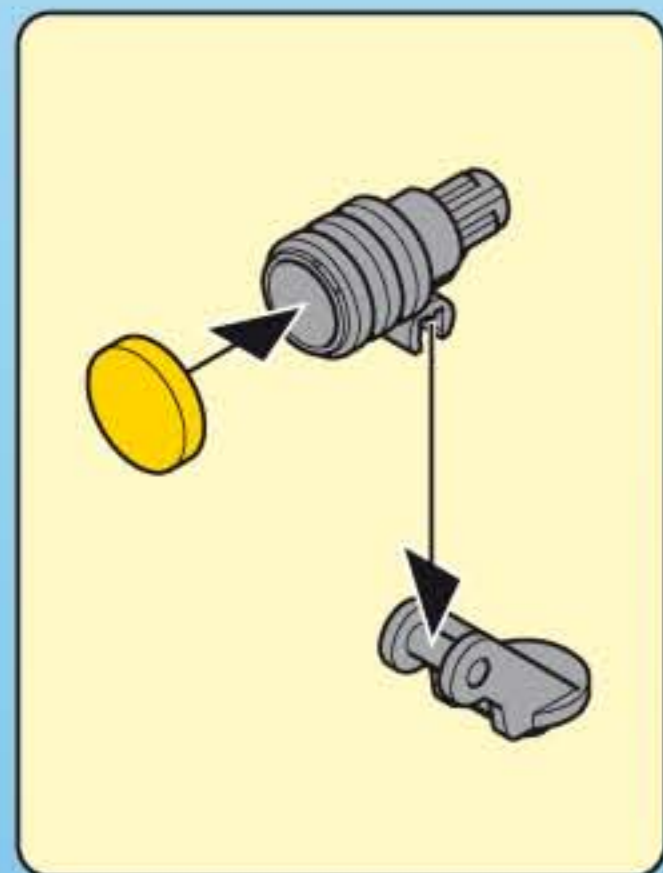
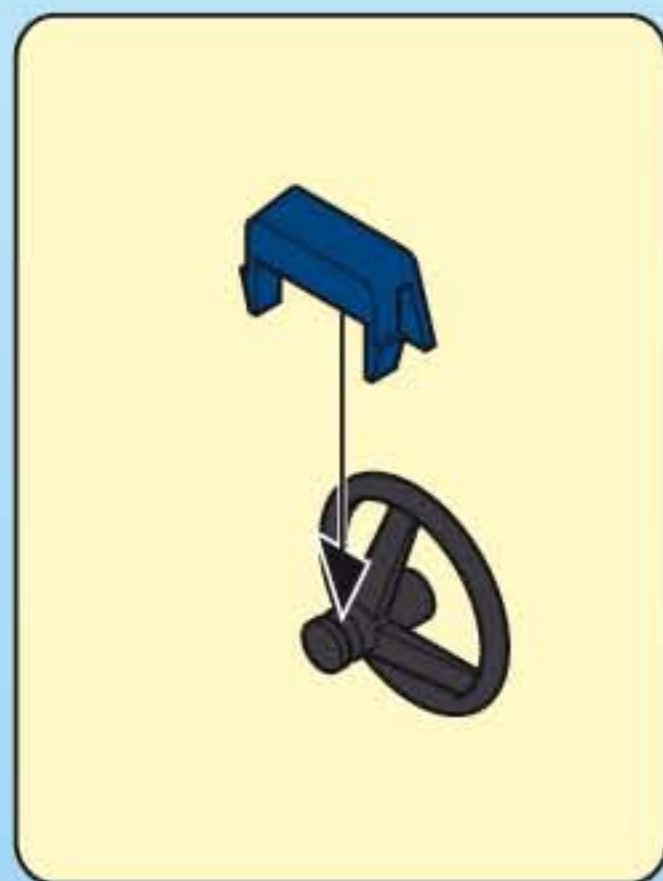

2

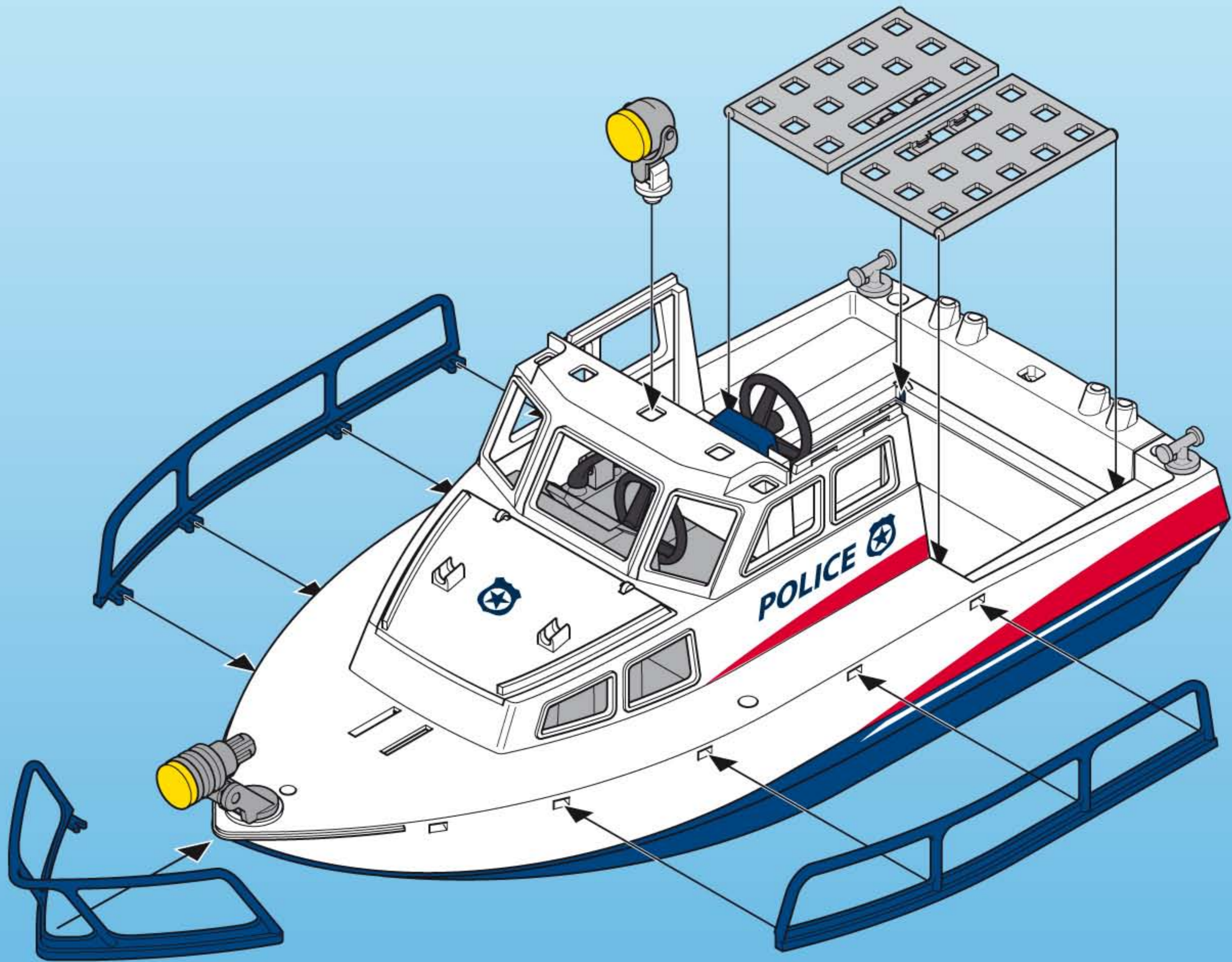
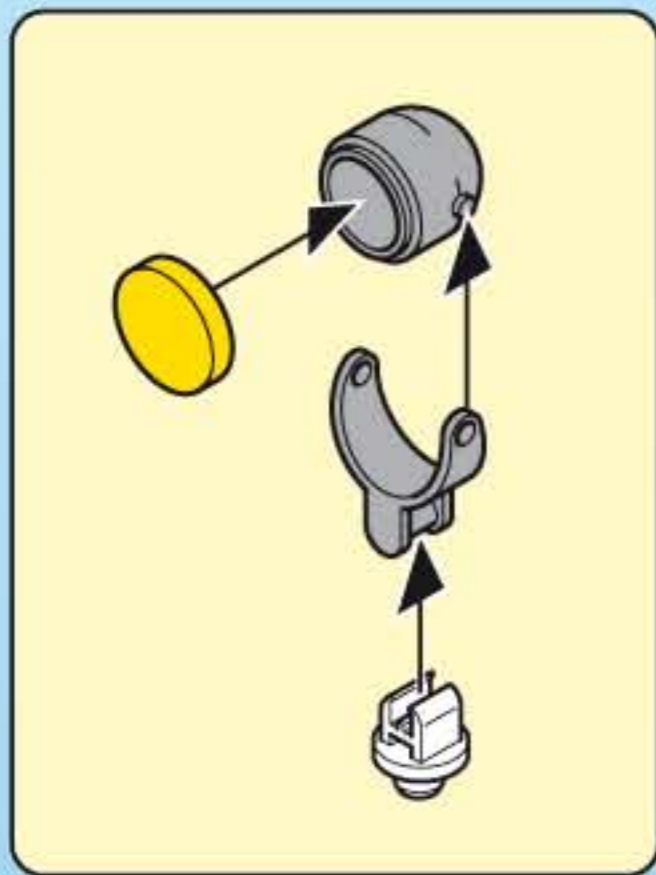

1

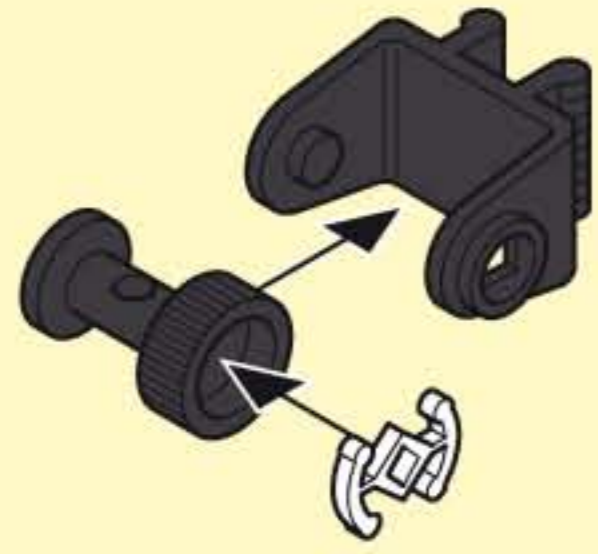

2

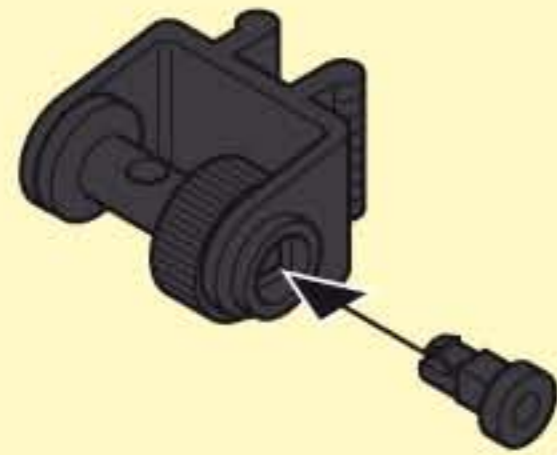

3



3

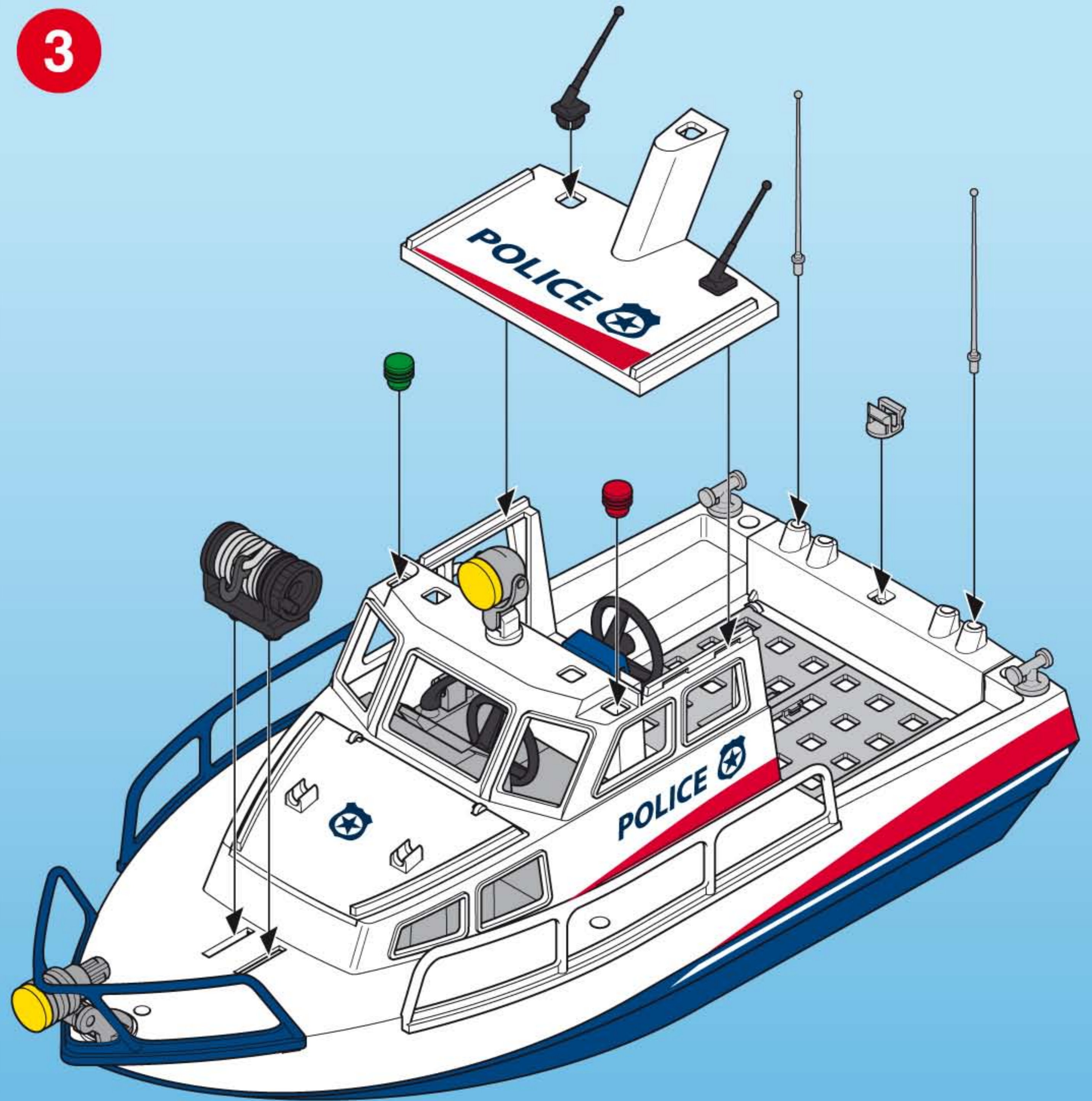

4

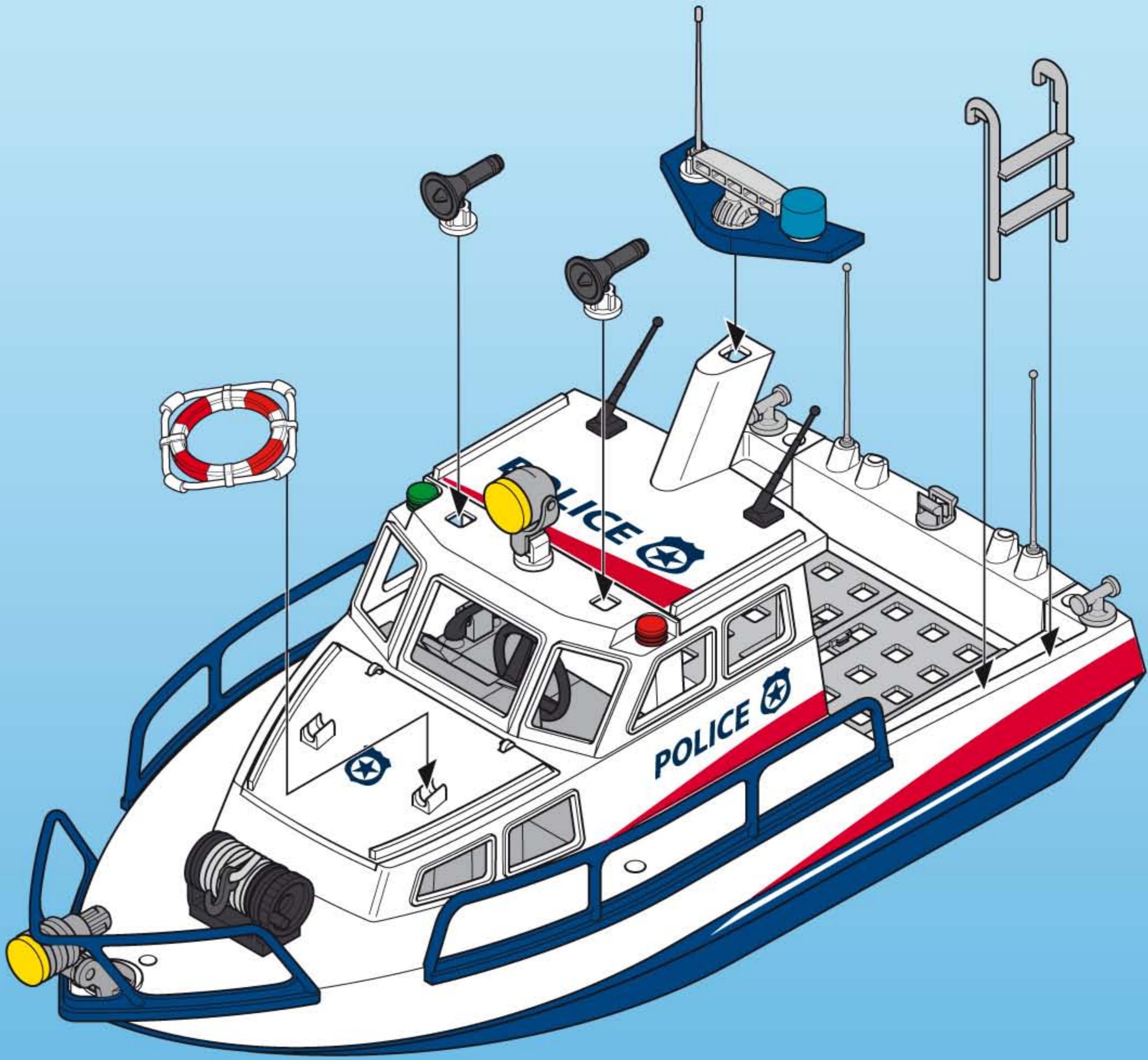
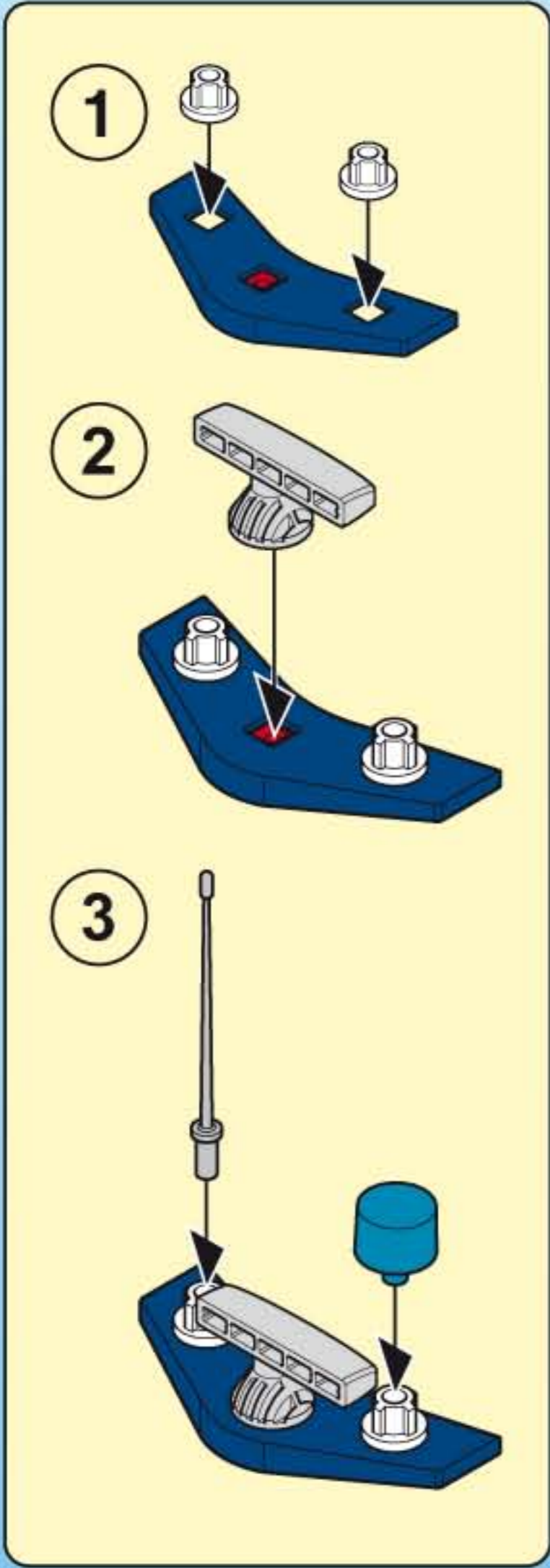

(D) (A) (CH) (L) (B) ACHTUNG!

Nur unter Aufsicht und nur in flachem Wasser benutzen.

(USA) (GB) (CDN) (M) (IRL) WARNING!

Only to be used in water in which the child is within its depth and under supervision

(F) (CDN) (B) (L) (CH) ATTENTION!

À n'utiliser qu'en eau où l'enfant a pied et sous surveillance.

(E) (MEX) ¡ ADVERTENCIA!

Se deberá utilizar solamente en el agua, donde el niño haga pie y bajo vigilancia.

(NL) (B) WAARSCHUWING!

Alleen gebruiken onder toezicht, in water waarin het kind kan staan.

(I) (CH) ATTENZIONE!

Utilizzare solo in acque dove il bambino tocca con i piedi e sotto sorveglianza.

(P) AVISO!

Utilizar apenas em águas em que a criança tenha pé e sob vigilância.

(DK) ADVARSEL!

Må kun anvendes under opsyn og på vanddybder, hvor barnet kan bunde.

(N) ADVARSEL!

Skal kun brukes i vann som ikke er for dypt for barnet, og der barnet er under tilsyn.

(S) (FIN) VARNING!

Får endast användas på grunt vatten och under uppsikt av vuxen.

(FIN) VAROITUS!

Käytetään ainoastaan matalassa vedessä, jossa lapsi voi seistä ja on aikuisen valvonnassa.

(H) FIGYELMEZTETÉS!

Mély vízben nem használható! Kérjük, kizárólag szülői felügyelettel használja kis vízben!

(CZ) VAROVÁNÍ!

Používat pouze v mělké vodě a pod dohledem!

(EST) HOIATUS!

Kasutamiseks ainult vees, kus lapse jalad ulatuvad põhja ja täiskasvanu järelevalve all.

(LV) BRĪDINĀJUMS!

Lietojams tikai seklā ūdenī un uzraudzībā.

(LT) DĖMESIO!

Naudoti prižiūrint suaugusiesiems ir tokiame gylyje, kur vaikas gali stovėti.

(SLO) OPOZORILO!

Uporabljeni samo v plitvi vodi in pod nadzorom.

(SK) UPOZORNENIE!

Používať len vo vode primerane hĺbokej dieťaťu a pod dohľadom.

(PL) UWAGA!

Tylko do użytku w wodzie płytkiej i pod nadzorem.

(TR) (CY) ΔΙΚΚΑΤ!

Sadece denetim altında ve sadece alçak sularda kullanın.

(GR) (CY) ΠΡΟΣΟΧΗ!

Να χρησιμοποιείται μόνο σε νερά όπου πατώνει το παιδί και κάτω από επίβλεψη.

(RO) AVERTIZARE!

Se folosește doar sub supraveghere și doar în apă mică.

(BG) ПРЕДУПРЕЖДЕНИЕ!

Да се използва само под наблюдение и в плитки води.

**(CN) 警告! 可供孩子在水中
使用，但必须在有人
监护的情况下。**

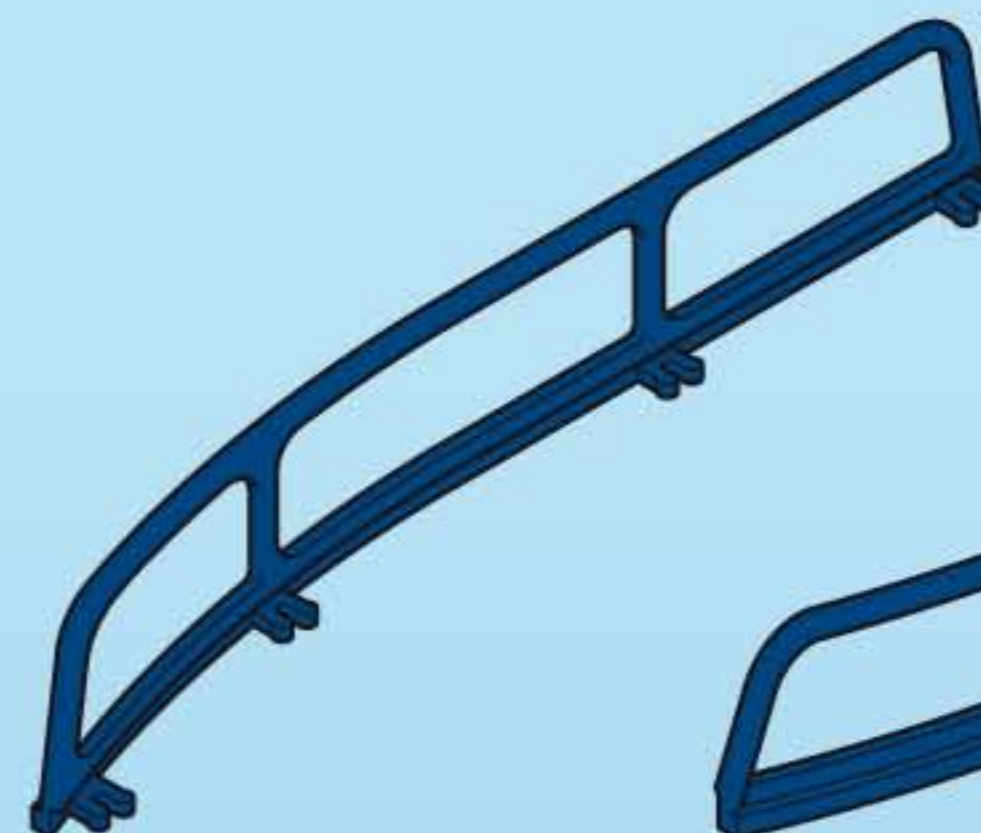

30 46 8940

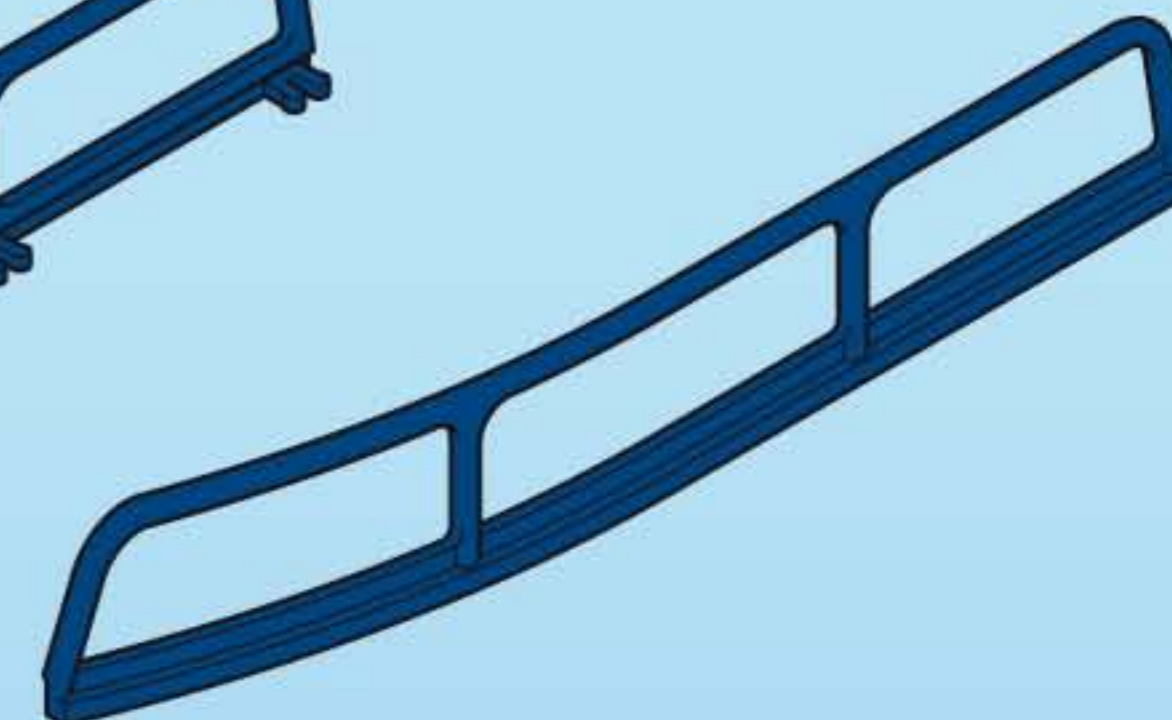

30 46 8660



30 25 0762

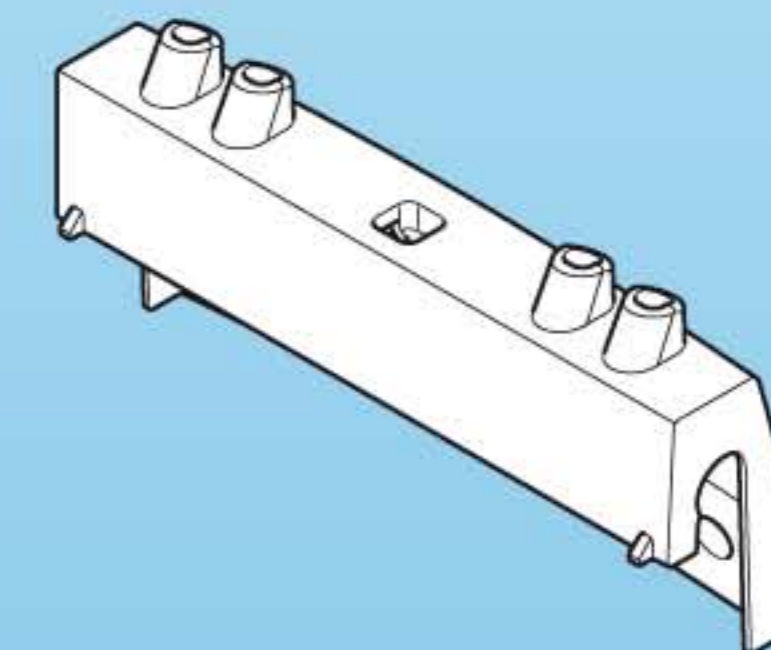

30 29 7720



30 63 9503



30 09 9150

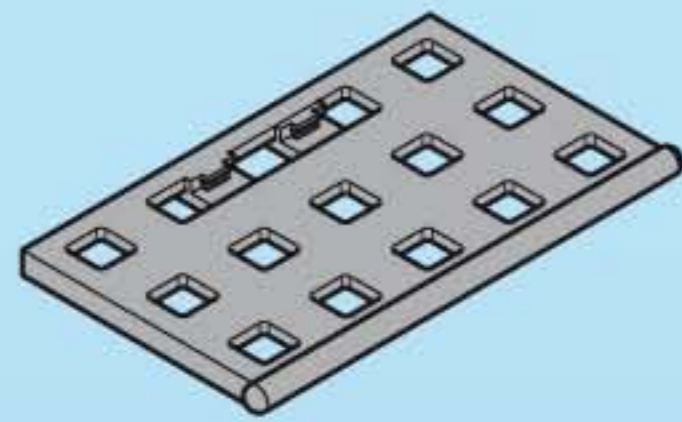

2x 30 21 0470

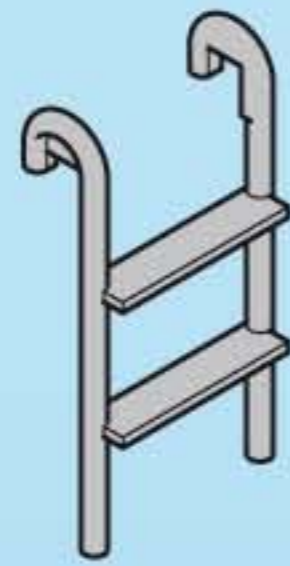

30 21 0380

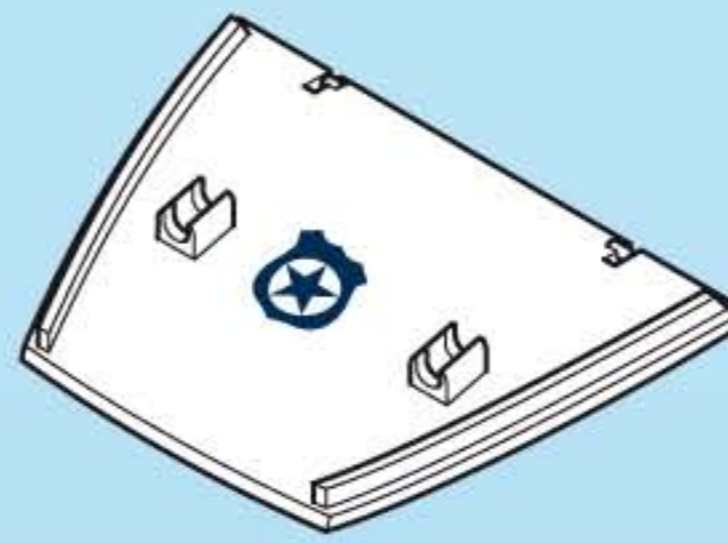

30 63 9493



2x 30 09 4330



30 03 2940



2x 30 22 6150

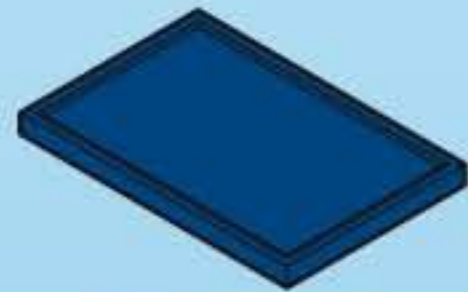

30 25 0662



30 04 4720



30 670212



30 23 2840



30 23 2850

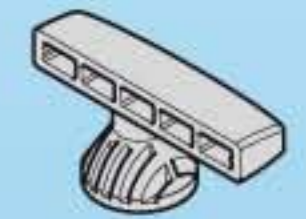

30 22 7480



30 021190



30 25 0642



30 89 8170



2x 30 29 7770



30 23 2860



2x 30 21 0570



2x 30 03 2040



30 03 2030



30 03 2060



30 224592



30 22 4582



30 21 0630



30 25 5170



30 07 5230



30 21 0550



30 21 0490



30 21 0480



4x 30 21 0540

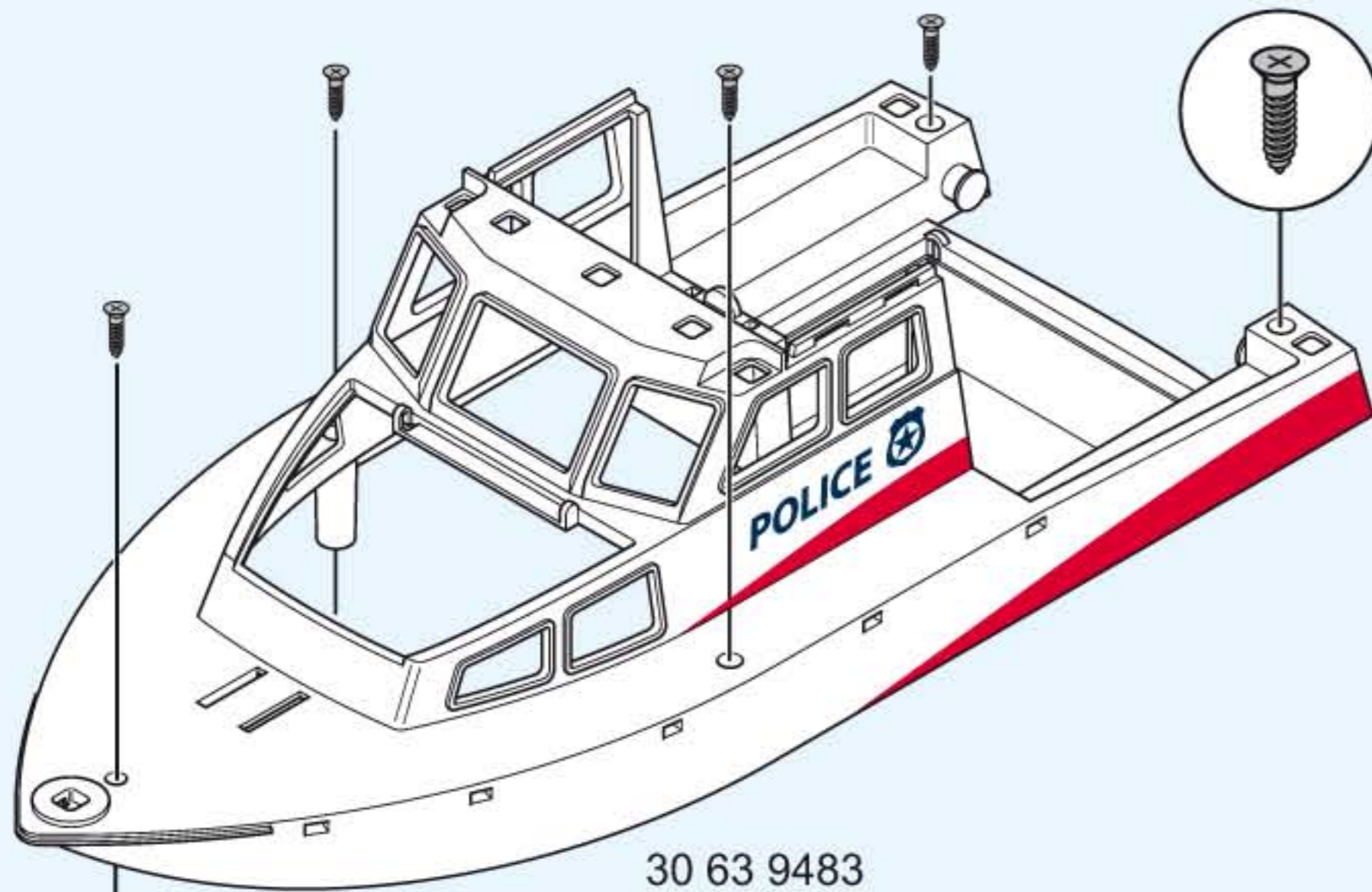

30 63 9483



30 82 8372

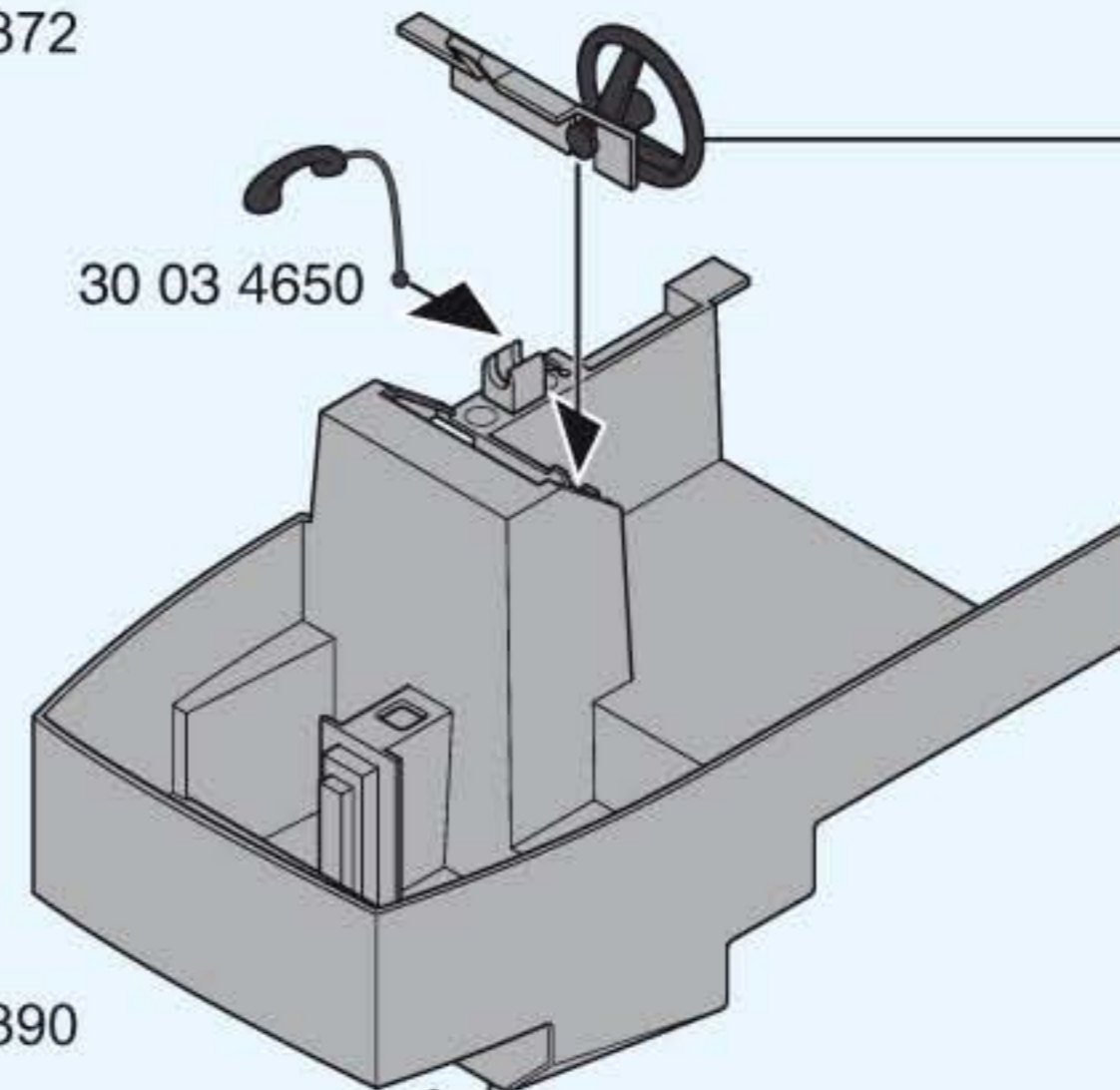

30 03 4650

30 21 0390

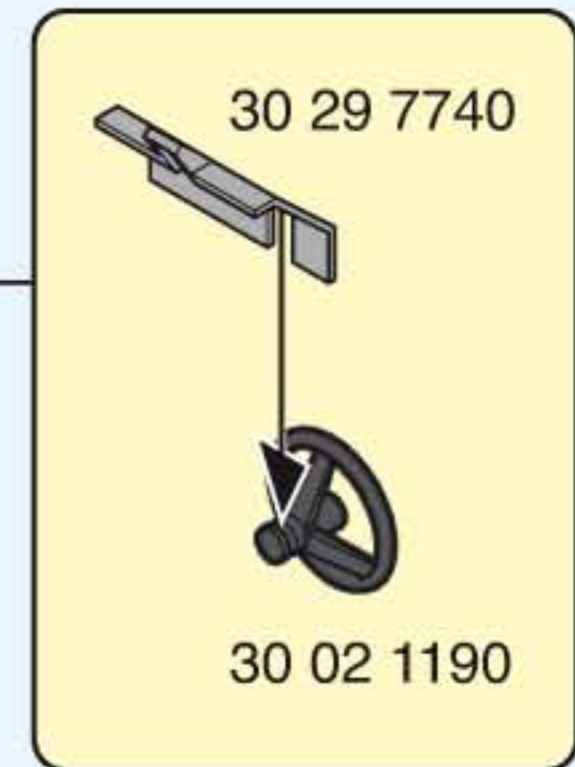

30 29 7740

30 02 1190

30 89 1470

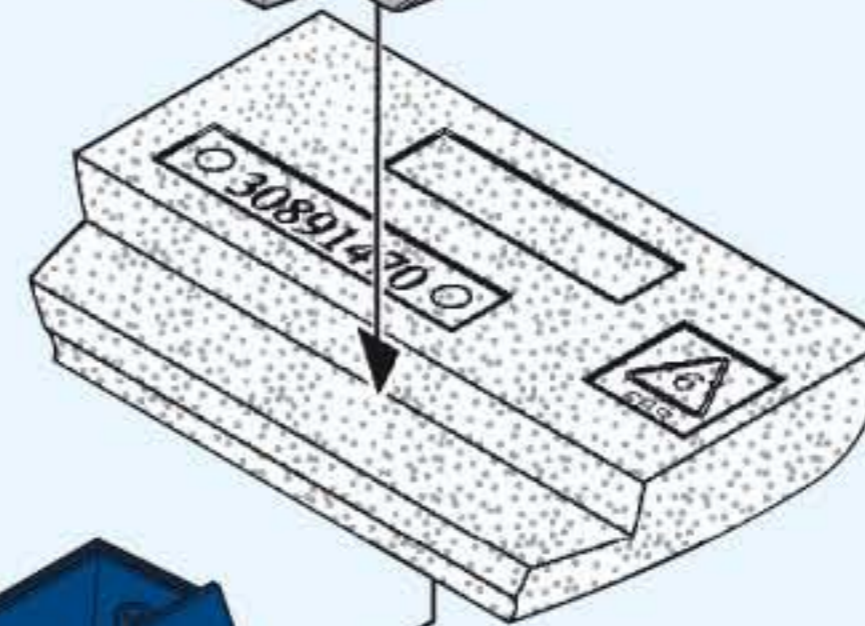

30 63 9473

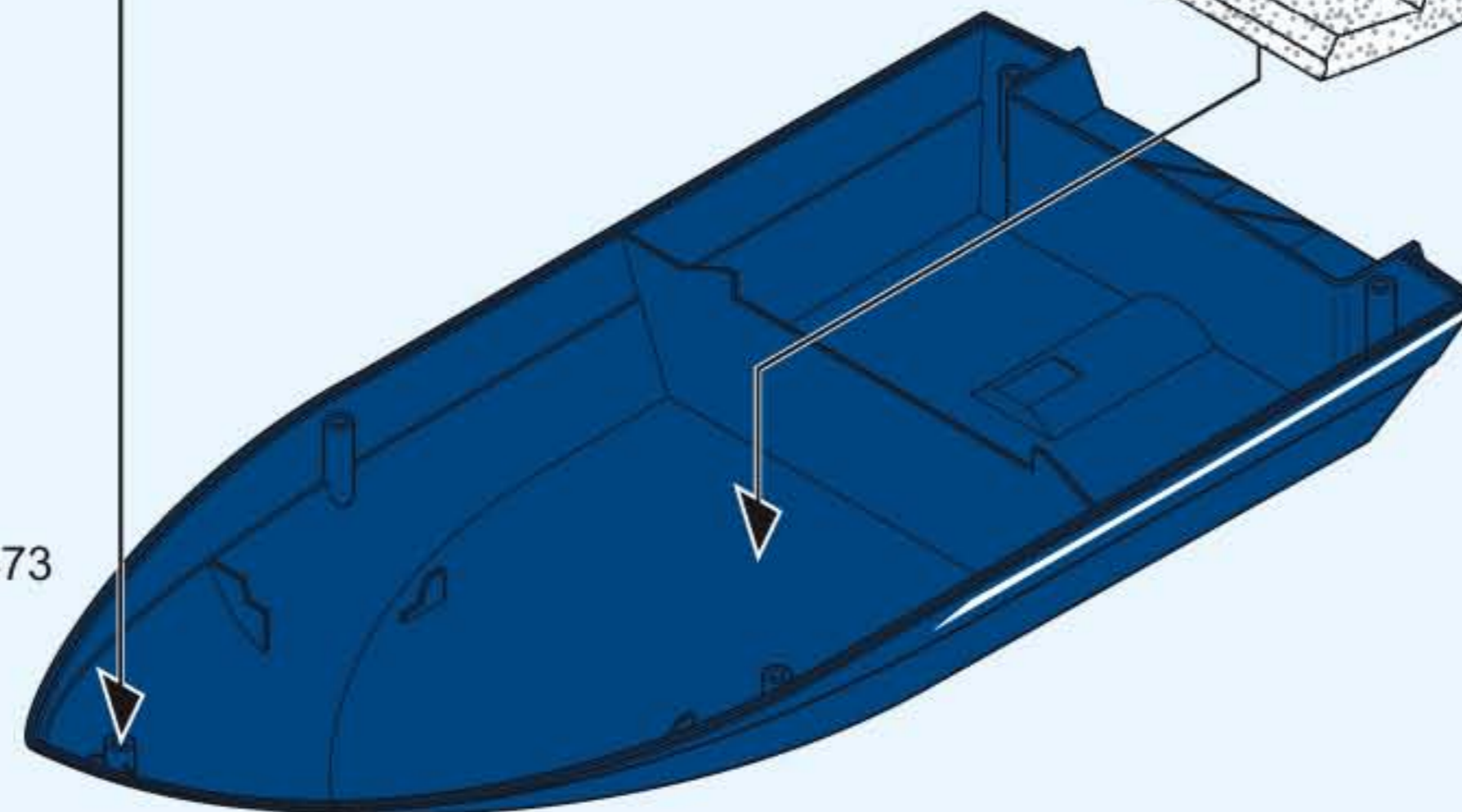

Serviceadressen finden Sie in allen Playmobil-Prospekten

Addresses of Customer Service Departments are shown in all Playmobil catalogues

L'adresse du service consommateurs est indiquée dans tous les catalogues Playmobil

Troverete gli indirizzi dei centri di assistenza in tutti i cataloghi Playmobil

In alle PLAYMOBIL catalogi vindt u het adres van onze klantendienst.

Las Direcciones de los Departamentos de Servicio al Consumidor se encuentran en todos los catálogos Playmobil

Η διεύθυνση του Γραφείου Εξυπηρέτησεως Πελατών είναι καταχωρημένη σε όλους τους καταλόγους Playmobil

pronounce: plāy-mō-bēēl